

可调测砧外径千分尺

- 符合JJF大外径千分尺国家计量技术规范
- 分度值: 0.01mm
- 调整测砧用于不同测量范围
- 棘轮测力
- 硬质合金测量面
- 配标准杆

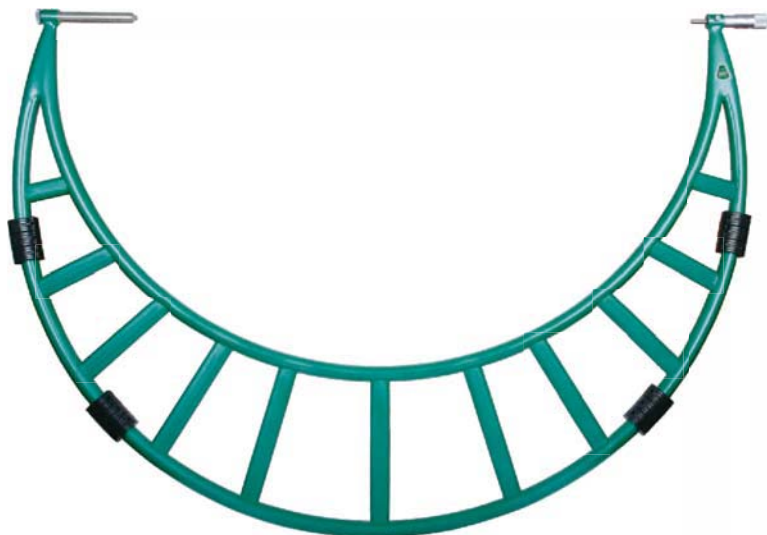

3205-1400C

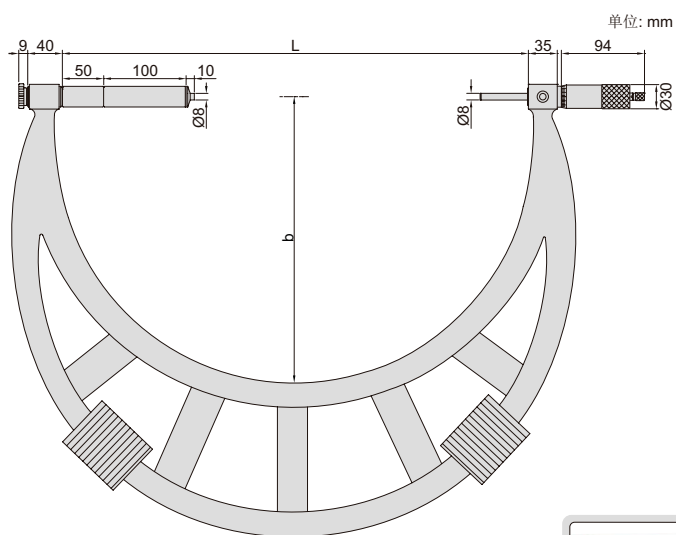

调整测砧用于不同测量范围

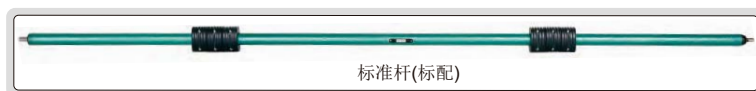

标准杆(标配)

(mm)

型号	测量范围	精度	L	b	标准杆(标配)
3205-1200C	1000-1200mm	22μm	1210	645	1050, 1150
3205-1400C	1200-1400mm	24μm	1410	745	1250, 1350
3205-1600C	1400-1600mm	28μm	1610	845	1450, 1550
3205-1800C	1600-1800mm	31μm	1810	945	1650, 1750
3205-2000C	1800-2000mm	34μm	2010	1045	1850, 1950
3205-2200C	2000-2200mm	40μm	2210	1145	2050, 2150
3205-2400C	2200-2400mm	44μm	2410	1245	2250, 2350
3205-2600C	2400-2600mm	48μm	2610	1345	2450, 2550
3205-2800C	2600-2800mm	52μm	2810	1445	2650, 2750
3205-3000C	2800-3000mm	56μm	3010	1545	2850, 2950